



FS Series

Motor Controller

Instruction & Installation Manual



Flight Systems Industrial Products
1015 Harrisburg Pike, Carlisle PA 17013

Phone: (717) 254-3747 Fax: (717) 254-3777
Toll Free: 1-800-333-1194 Web site: www.fsip.biz

Functions and Features

The following is a list of available features not included in every control. See ordering instructions for how to order listed features.

Standard Features:

See potentiometer adjustments on page 3.

Controlled Acceleration

An adjustable function that allows smooth acceleration on vehicles of varying weights and speeds.
See potentiometer adjustments on page 3.

Current Limit

An adjustable function that renders self-protection to the control and the traction motor.
See potentiometer adjustments on page 3.

Thermal Protection

A protection circuit that reduces control output, if needed, to maintain rated component temperature. Switching frequency is reduced at ~ 60° C.

Accelerator Volts Hold Off (Option)

This feature assures that the accelerator is calling for low speed operation at start up.

Plug Braking (Option)

An adjustable function that allows smooth braking on vehicles of varying weights and speeds.

High Frequency Operation

This feature provides oscillation frequency of 13 kHz. The high oscillation rate allows for quieter operation, higher average motor current with lower peak motor currents, less ripple current at the motor, and less motor heating.

Reversed Battery Protection

(With Line Contactor and Diode) This function disables the operation of the control if the battery connections are reversed.

Low Voltage

The control is designed for use down to the following voltages:

24/36V: 16V cutout

36/48V: 19V cutout

48/72V: 25V cutout

72/96V: 36V cutout

120/144V: 60V cutout

The control will not operate when the cutout voltage is reached.

Specifications*

Package dimensions:6.75" L x 5.75" W x 2.80" H size 'S'
.....8.75" L x 5.75" W x 2.80" H size 'L'	
.....	See Outline Below
Maximum armature current:480 Amps size 'S'
.....700 Amps size 'L'	
Maximum plug current:300 A for 3 sec 'S'
.....450 A for 3 sec 'L'	
Operating temperature:-40°C to +50°C
Storage temperature-40°C to +85°C
Thermal Protection:90°C

Accelerator Input5k to 0 Ohms, 0 to 5k Ohms,0-5V (3 wire) or Special config.
Power DevicesMOSFETS
Motor ReversingContactors or Manual Switch
Operating frequency (Armature):13 kHz
ModulationPWM
Adjustment MethodTrimpot
Reverse Battery ProtectionWith Line Contactor
Low Battery OperationYes
Accelerator Volts Hold OffYes

* Specifications list typical functions and features that are available. Actual control feature content will vary, depending on application needs.

Installation Tips:

Using heat transfer compound (FSIP P/N: 43-8012-30) between the motor control and the mounting plate of the vehicle will enhance performance on heavy-duty applications. A thin coating that covers the mounting surface gives the best heat transfer.

Do not allow controller to come in direct contact with battery acid, water, or power washing. These contaminants can get inside controller and cause circuit board damage which will cause premature failure and may void warranty.

- Always use safe practices while working on electric vehicles.
- When appropriate, lift the drive wheels off the ground.
- Disconnect the batteries before removing or installing controllers.
- Verify all electrical connections are secure. Improper connections will cause heat and could damage drive system.

Warranty and Service

This product is covered by a 12-month warranty. Worldwide technical assistance and service are available from local FSIP representatives.

Ordering Information:

Part Number

51- 42 L 700 N H 0 S
BASIC ARG 1 ARG 2 ARG 3 ARG 4 ARG 5 ARG 6 ARG 7

ARG 1 Voltage

30 - 24 to 36 VDC
 42 - 36 to 48 VDC
 48 - 48 VDC
 60 - 48 to 72 VDC
 72 - 72 VDC
 84 - 72 to 96 VDC
 HV - 120 to 144 VDC

ARG 2 Unit Size

S - 5.75" X 6.75" X 2.8"
 I_{max} VDC
 500 24 through 72V

 L - 5.75" X 8.75" X 2.8"
 I_{max} VDC
 700 24 through 72V
 600 72 through 96V
 125 120 through 144V

ARG 3 Current Limit (examples)

275 - 275 Amps
 500 - 500 Amps
 600 - 600 Amps
 700 - 700 Amps

ARG 4 Plugging Option

P - Plugging
 N - No Plugging

ARG 5 Accelerator Volts Hold Off

H - Unit has Hold Off
 N - No Hold Off

ARG 6 Accelerator Input

0 - 0 to 5K Ohms
 5 - 5K to 0 Ohms
 V - 3-wire 5k pot,
 Club Car V-Glide
 S - Special setting
 N - No Accelerator Input (KS enable)

ARG 7 Features

S - Standard
 P - Premium

Potentiometer Adjustment.

The potentiometers are designed to be adjusted with a small trimmer or screwdriver.

Current Limit (CL) – Adjust potentiometer CW (clockwise) to increase maximum current limit. The current is adjustable from approximately 50% to 100% of controller rating.

Controlled Acceleration (CA) – Adjust potentiometer CW to increase acceleration. The acceleration ramp is adjustable from approximately 0.5 to 5 seconds. The factory setting is 1.2 seconds.

Plugging Adjustment (PL) – Adjust potentiometer CW to increase intensity of plugging. Be sure when setting Plugging to make for smooth forward to reverse transition. Plugging current is adjustable from approximately 10% to 100% of specified limit.

Outline (For Reference Only)

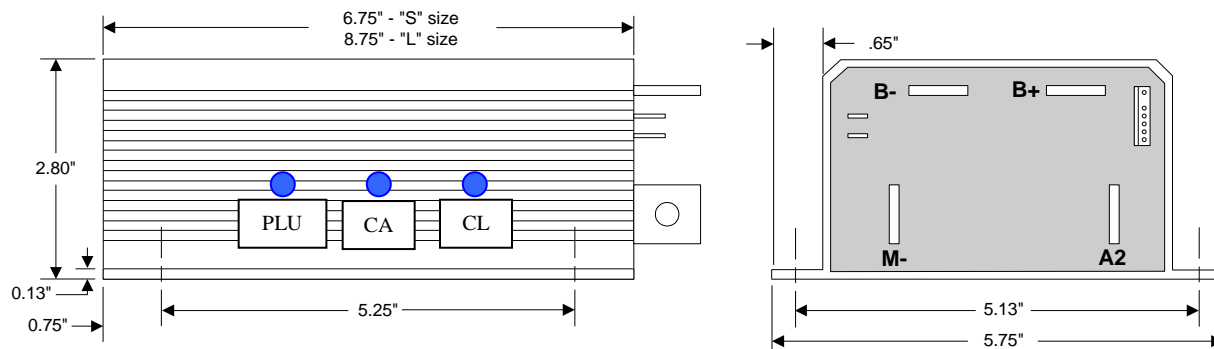

Elementary Diagrams (For Reference Only)

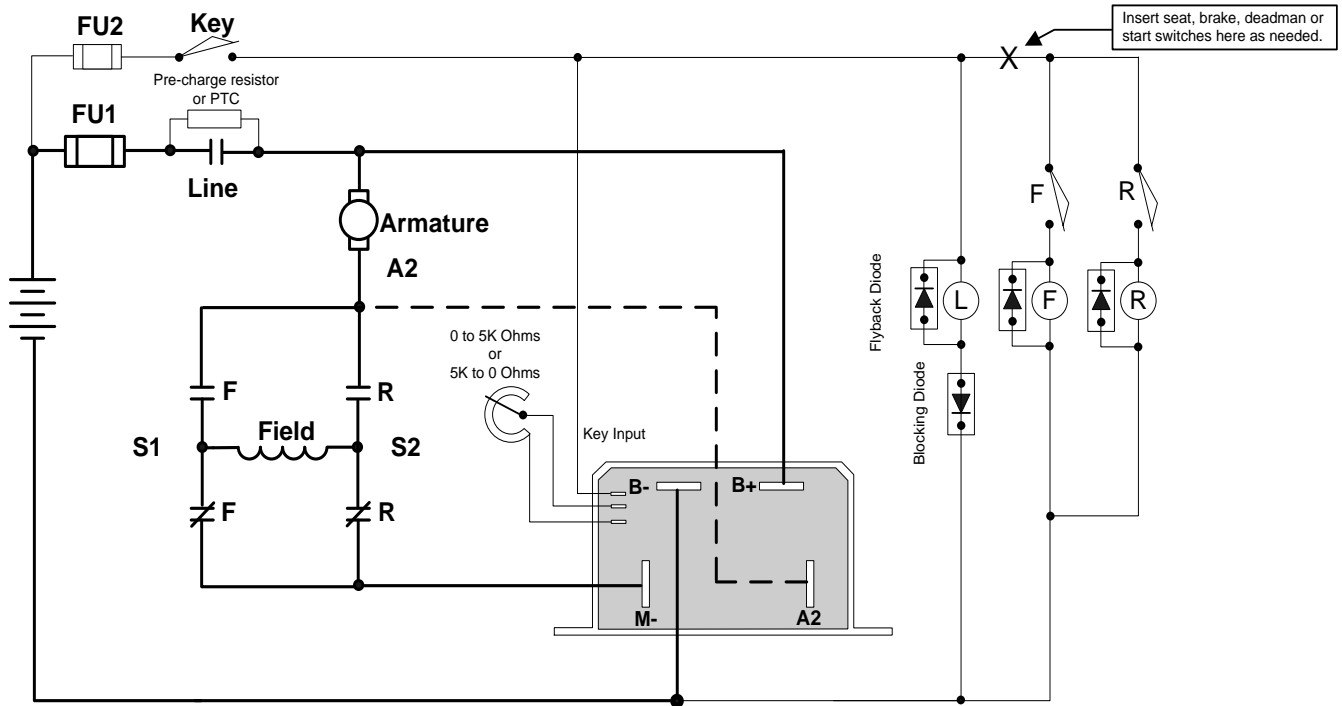

Typical EV wiring with F & R Contactors, Hold Off option (2-wire Accelerator shown)
Dotted line shows units with optional Plugging

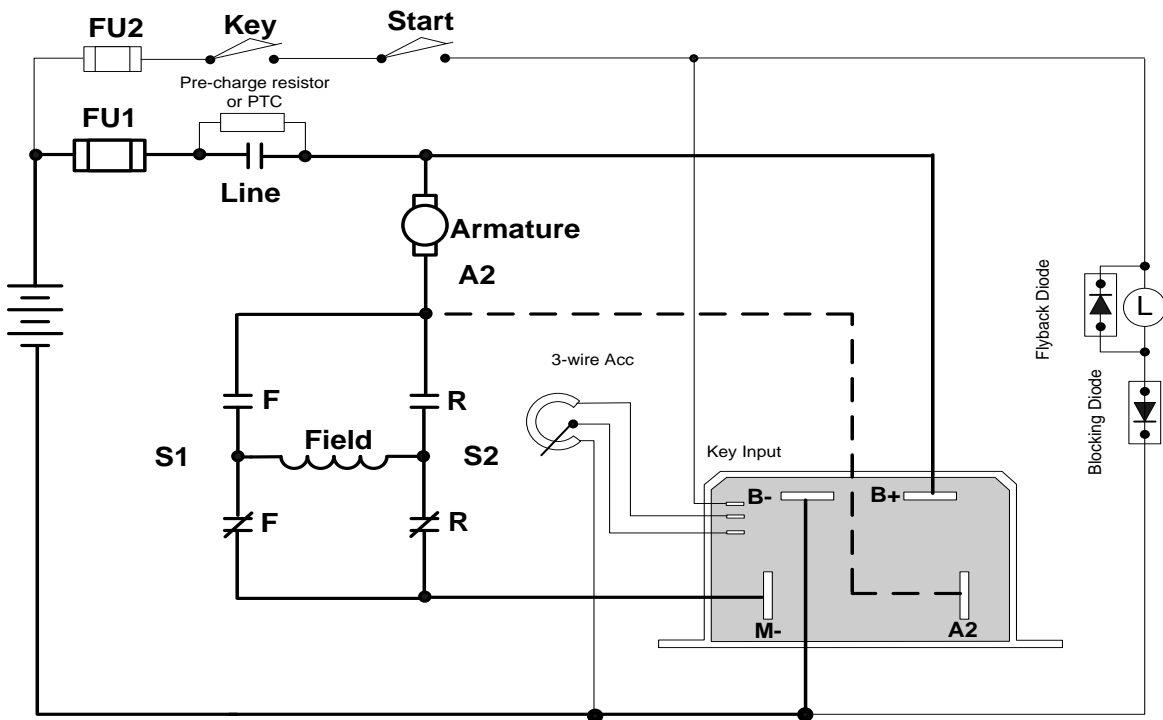

Typical Golf Car wiring with F & R switch, no Hold Off option (3-wire Accelerator shown)
Dotted line shows units with optional Plugging

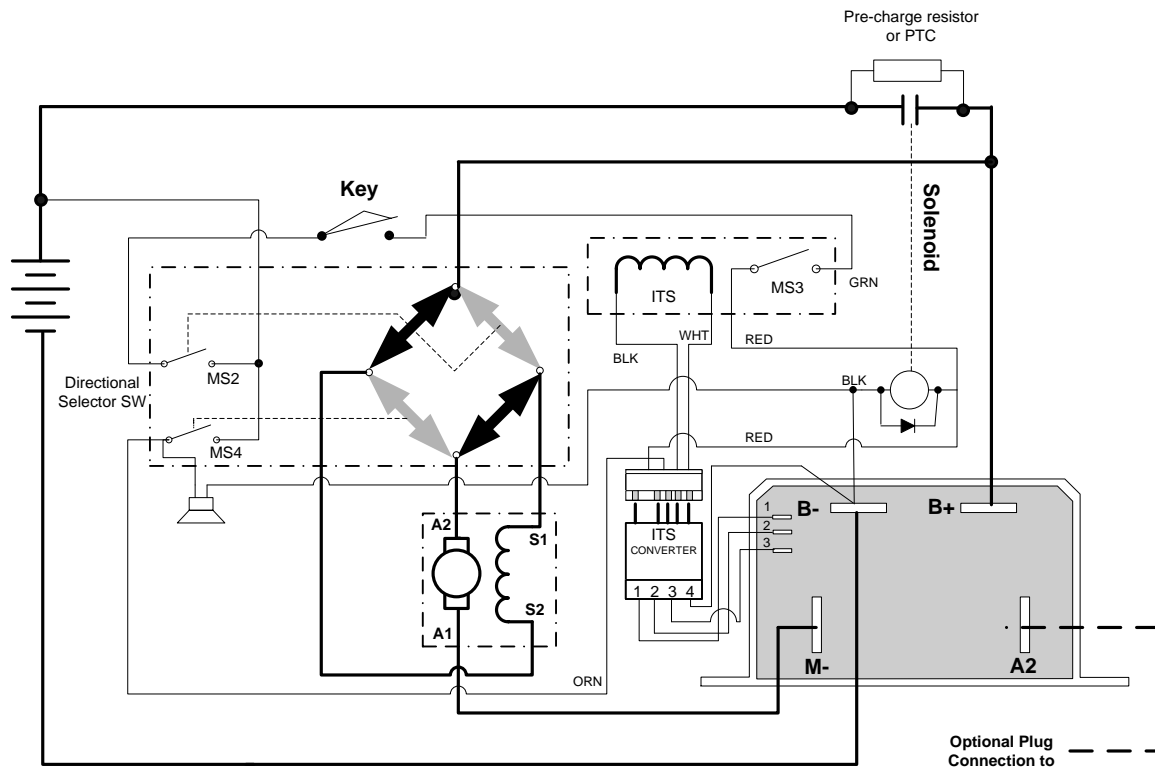

MS2 is closed when directional selector sw is in FWD or REV
 MS3 is activated by accelerator pedal
 MS4 is closed by directional selector switch in REV only

Typical EZGO Golf Car wiring with F & R switch using ITS Converter

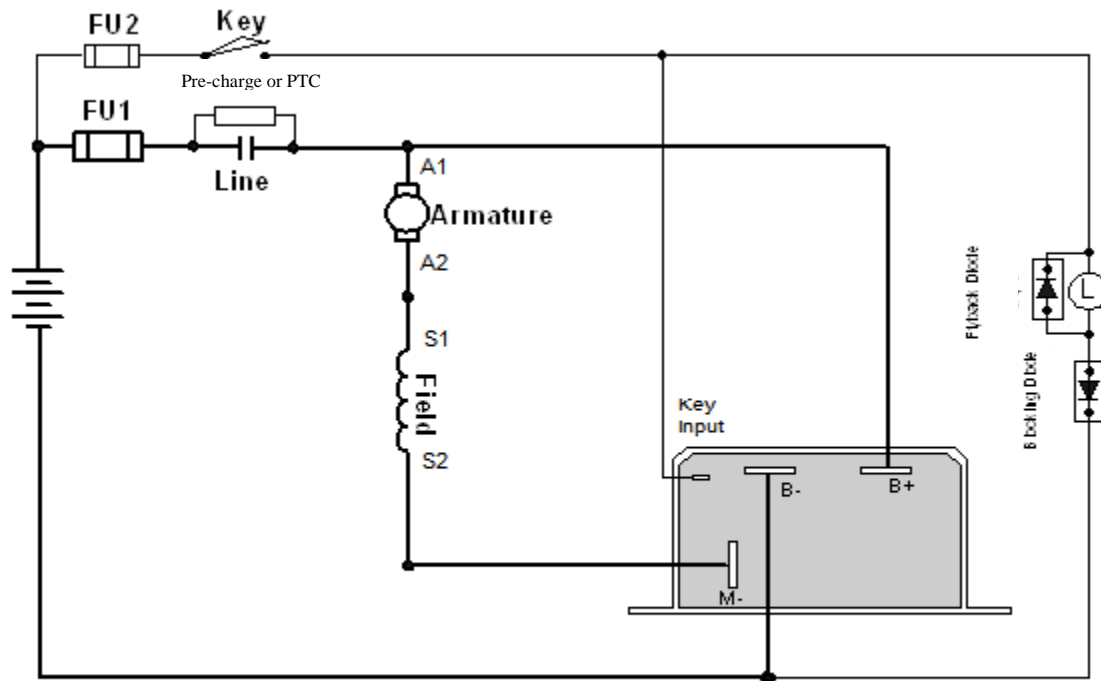

Typical wiring for pump or soft start applications shown, applies to NNNS type controller only.

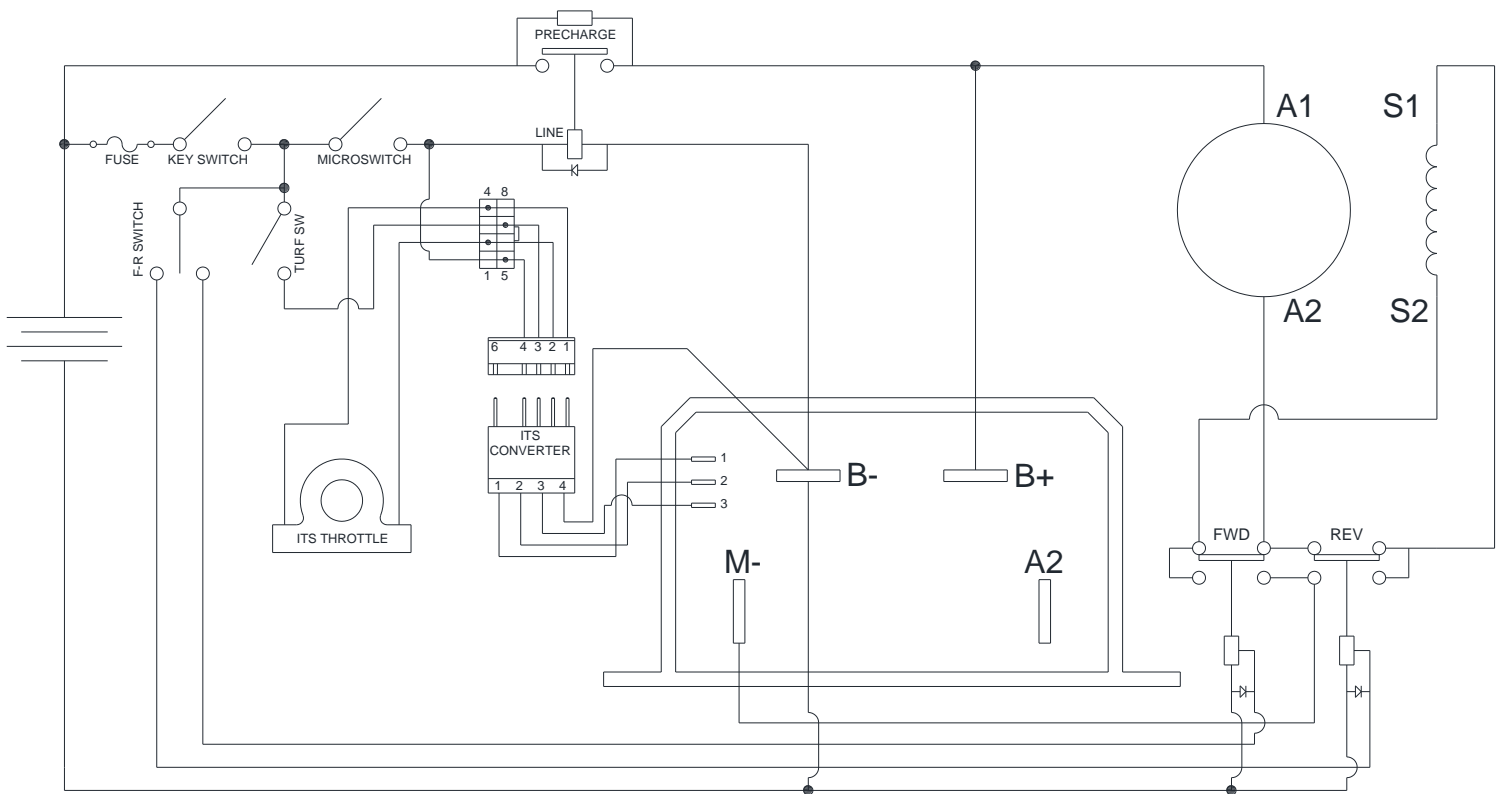

Typical Ruff-N-Tuff Golf Car wiring with F & R switch using ITS Converter

Original 8 Pin Connector

- Pin 2 – ITS Input to Pin 2 of ITS Converter
- Pin 4 – ITS Positive to Pin 1 of ITS Converter
- Pin 5 – Key Switch to Pin 4 of ITS Converter
- Pin 7 – Turf Switch to Pin 3 of ITS Converter

ITS Converter

- Pin 1 (Red) – B+ volts with accelerator depressed (Start Switch) wired to Pin 1 of STAR
- Pin 2 (Blue) – 5vdc (wired to Pin 2 of STAR)
- Pin 3 (White) – 0 to 5vdc (open to full throttle) wired to pin 3 of STAR.
- Pin 4 (Black) – Wired to B- post of STAR controller.