

Kelly KHB High Power Brushless Motor Controller User' s Manual

Devices Supported:

KHB72601	KHB12101
KHB72701	KHB14201
KHB72101	KHB14301
KHB12151	KHB14401
KHB12201	KHB14601
KHB12251	
KHB12301	
KHB12401	
KHB12601	
KHB12801	

Contents

Chapter1	Introduction.....	2
1.1	Overview.....	2
Chapter 2	Features and Specifications.....	3
2.1	General functions.....	3
2.2	Features.....	4
2.3	Specifications.....	5
2.4	Naming Regulations.....	5
Chapter 3	Wiring and Installation.....	6
3.1	Mounting the Controller.....	6
3.2	Connections.....	8
3.2.1	Front Panel and back panel of KHB Motor Controller:.....	8
3.2.2	Wiring of KHB Motor Controller.....	12
3.3	Communication Port.....	13
3.4	Installation Check List.....	13
Chapter 4	Maintenance.....	14
4.1	Cleaning.....	14
4.2	Configuration.....	14
Table 1:	LED CODES.....	15
Contact Us:	17

Chapter 1 Introduction

1.1 Overview

This manual introduces the Kelly high power BLDC motor controllers' features, their installation and their maintenance. Read the manual carefully and thoroughly before using the controller. If you have any questions, please contact the support center of Kelly Controls.

Kelly' s programmable motor controllers provide high efficient, smooth and quiet controls for electric motorcycles, forklifts, hybrid vehicles, electric vehicles and electric boats, as well as industrial motor speed or torque control. It uses high power MOSFET' s and, PWM to achieve efficiencies of up to 99% in most cases. A powerful microprocessor brings in comprehensive and precise control to the controllers. It also allows users to adjust parameters, conduct tests, and obtain diagnostic information quickly and easily.

Chapter 2 Features and Specifications

2.1 General functions

- (1) Extended fault detection and protection. The LED flashing pattern indicates the fault sources. Green LED indicates normal operation. Controller will shut down in some fault conditions.
- (2) Monitoring battery voltage. It will stop driving if the battery voltage is too high and it will progressively cut back motor drive power as battery voltage drops until it cuts out altogether at the preset “Low Battery Voltage” setting.
- (3) Built-in current loop and over current protection.
- (4) Configurable motor temperature protection range.
- (5) Current cutback at low temperature and high temperature to protect battery and controller. The current begins to ramp down at 90°C case temperature, shutting down at 100°C.
- (6) Enhanced regen brake function. A novel ABS technique provides powerful and smooth regen.
- (7) The controller keeps monitoring battery recharging voltage during regenerative braking, progressively cutting back current as battery voltage rises then cutting off regen altogether when voltage goes too high.
- (8) Pulsed reverse alarm output.
- (9) 3 switch inputs which are activated by connection to Ground. Default to throttle switch, brake switch and reversing switch.
- (10) 3 analog 0-5V inputs that default to throttle input, brake input and motor temperature input.
- (11) Provision of a +5 volt output to supply various kinds of sensors, including Hall effect type.
- (12) Main contactor driver. Cutting off the power if any fault is detected.
- (13) Current meter to display both drive and regen current. Save shunt.
- (14) 3 hall position sensor inputs. Open collector, pull up provided.
- (15) Maximum reverse speed is configurable to half of max forward speed.
- (16) Configurable and programmable with a host computer though RS232 or USB. Provide free GUI which can run on Windows XP/2000, Windows 7 and Vista(recommend using Kelly Standard USB To RS232 Converter).
- (17) Configurable boost switch. Enables the maximum output power achievable if the switch is turned on.
- (18) Configurable economy switch. Limits the maximum current to half if the switch is turned on.
- (19) Maximum reverse power is configurable to half power.
- (20) Configurable 12V brake signal input, in lieu of motor temperature sensor.
- (21) Optional joystick throttle. A bi-symmetrical 0-5V signal for both forwarding and reversing
- (22) Configurable motor over-temperature detection and protection with the recommended thermistor KTY84-130.
- (23) Optional CAN bus.
- (24) Supply voltage 8V-30V

Caution! Regeneration has braking effect but does not replace the function of a mechanical brake. A mechanical brake is required to stop your vehicle. Regen IS NOT a safety feature! Controller may stop regen, without warning, to protect itself or the battery(it won't protect you!).

2.2 Features

- 1) Opto-isolated technology achieve stability.
- 2) Intelligence with powerful microprocessor.
- 3) Synchronous rectification, ultra low drop and fast PWM to achieve very high efficiency.
- 4) Electronic reversing.
- 5) Voltage monitoring on 3 motor phases, bus, and power supply.
- 6) Voltage monitoring on voltage source 12V and 5V.
- 7) Current sense on all 3 motor phases.
- 8) Current control loop.
- 9) Hardware over current protection.
- 10) Hardware over voltage protection.
- 11) Support torque mode, speed mode, and balanced mode operation.
- 12) Configurable limit for motor current and battery current.
- 13) Low EMC.
- 14) LED fault code.
- 15) Battery protection: current cutback, warning and shutdown at configurable high and low battery voltage.
- 16) Rugged aluminum housing for maximum heat dissipation and harsh environment. Support fan or water cooling.
- 17) Rugged high current terminals, and rugged aviation connectors for small signal.
- 18) Thermal protection: current cut back, warning and shutdown at high temperature.
- 19) Configurable 60 degree or 120 degree hall position sensors.
- 20) Support motors with any number of poles. Up to 40,000 electric RPM standard. Optional high speed 70,000 ERPM, and ultra high speed 100,000 ERPM.
(Electric RPM = mechanical RPM * motor pole pairs).
- 21) Support three modes of regenerative braking: brake switch regen, release throttle regen, 0-5K or 0-5V analog signal variable regen for KHB and HP controllers.
- 22) Configurable high pedal protection: the controller will not work if high throttle is detected at power on.
- 23) Current multiplication: Take less current from battery, output more current to motor.
- 24) Easy installation: 2 or 3-wire pot, or hall sensor throttle can work with KHB and HIP controllers.
- 25) Remote fault code LED driver.
- 26) Current meter output.
- 27) Standard PC/Laptop computer is used to do programming. No special tools needed.
- 28) User program provided. Easy to use. No cost to customers.

2.3 Specifications

- (1) Frequency of Operation: 16.6kHz.
- (2) Standby Battery Current depending on the model: usually less than 2mA.
- (3) 5V Sensor Supply Current: 40mA.
- (4) Controller supply voltage range, PWR, 8 to 30V (24V preferred)
- (5) Controller input power, PWR: less than 10W.
- (6) Configurable battery voltage range, B+. Max operating range: 18V to 136V for controller rated equal 120V. 18V to 180V for controller rated equal 144V.
- (7) Standard Throttle Input: 0-5 Volts(3-wire resistive pot), 1-4 Volts(hall active throttle).
- (8) Analog Brake and Throttle Input: 0-5 Volts. Producing 0-5V signal with 3-wire pot.
- (9) Reverse Alarm, Main Contactor Coil Driver, Meter.
- (10) Full Power Operating Temperature Range: 0°C to 50°C (controller case temperature).
- (11) Operating Temperature Range:-30 °C to 90 °C ,100 °C shutdown(controller case temperature).
- (12) Motor Current Limit, 1 minute: 150A - 1000A, depending on the model.
- (13) Motor Current Limit, continuous: 75A - 500A, depending on the model.
- (14) Max Battery Current : Configurable..

2.4 Naming Regulations

The naming regulations of Kelly KHB BLDC motor controllers:

KHB12601

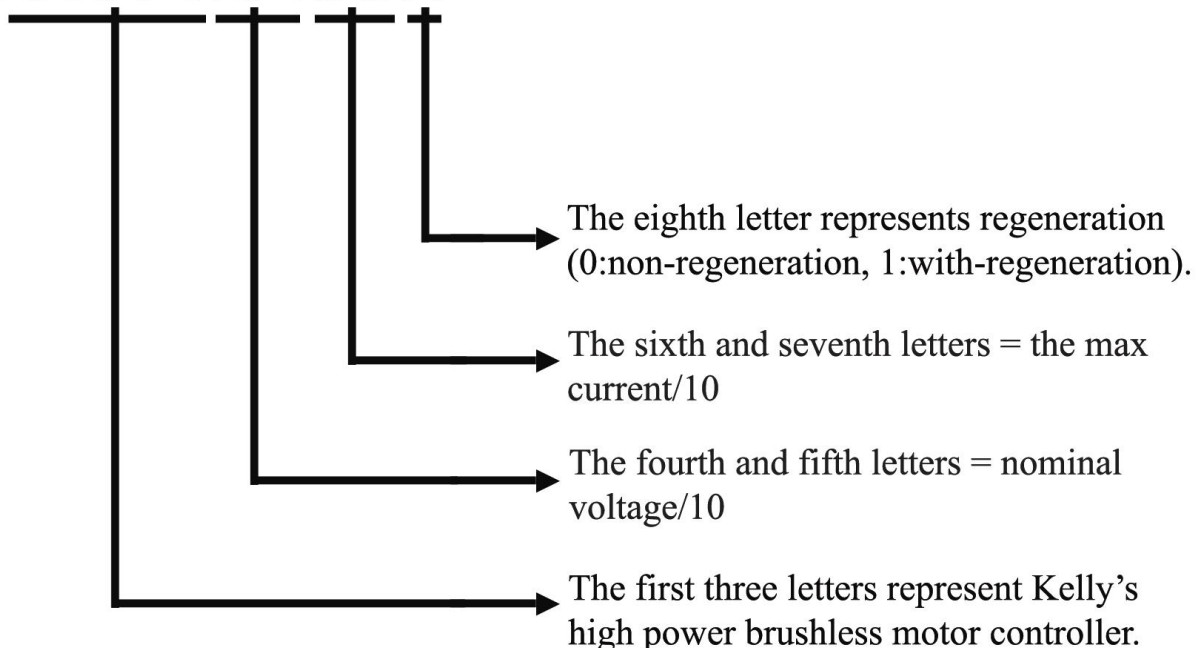

Chapter 3 Wiring and Installation

3.1 Mounting the Controller

The controller can be oriented in any position which should be as clean and dry as possible, and if necessary, shielded with a cover to protect it from water and contaminants.

To ensure full rated output power, the controller should be fastened to a clean, flat metal surface with six screws. Applying silicon grease or some other thermal conductive material to contact surface will enhance thermal performance.

Proper heat sinking and airflow are vital to achieve the full power capability of the controller.

The case outline and mounting holes' dimensions of KHB Controllers:

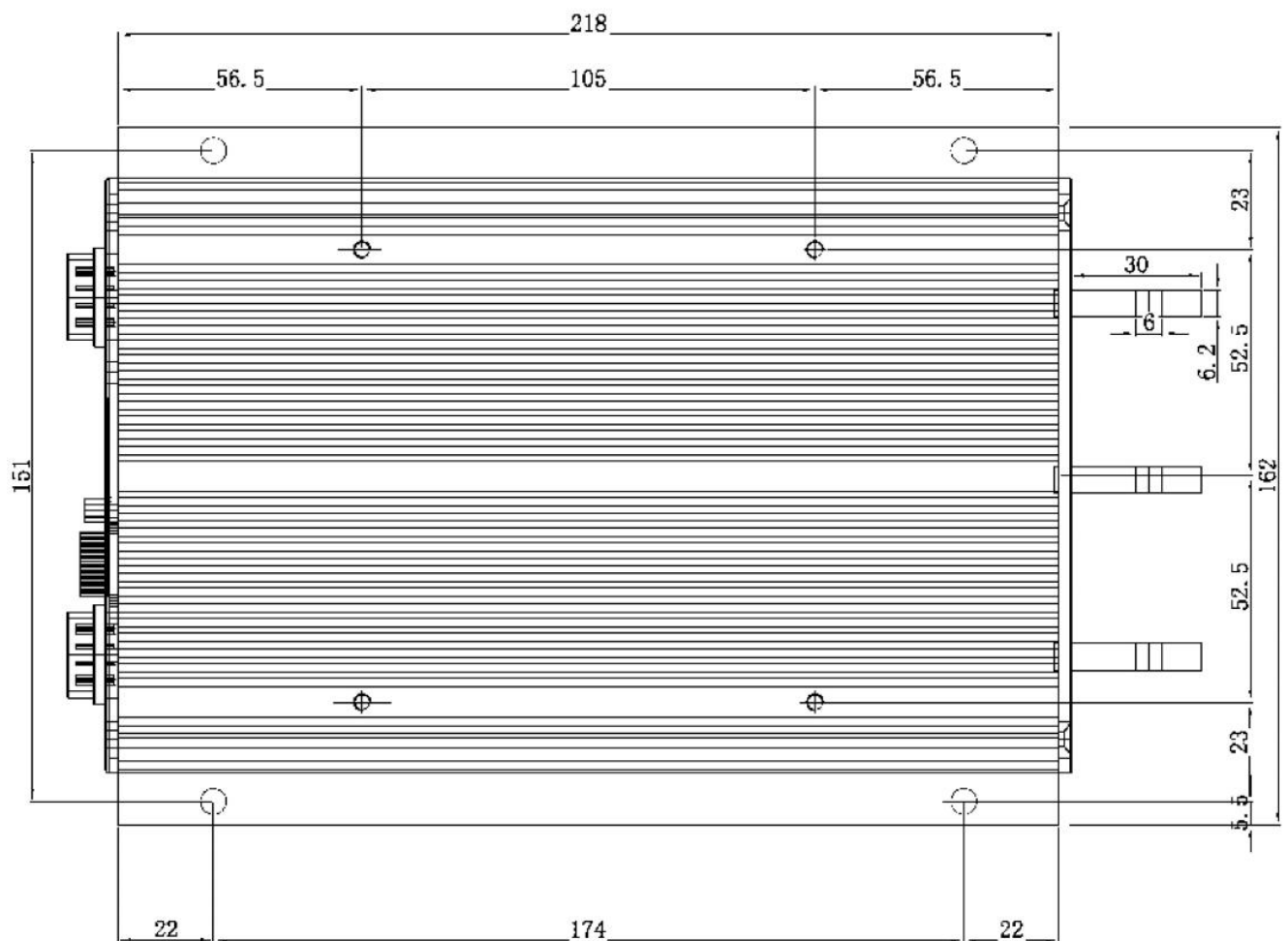

Height: 84 millimeters

Length: 218 millimeters

Figure 1: KHB mounting holes' dimensions (dimensions in millimeters)

Controller models with above dimension: KHB12151, KHB12201, KHB12251

KHB12301, KHB12401

KHB14201, KHB72601

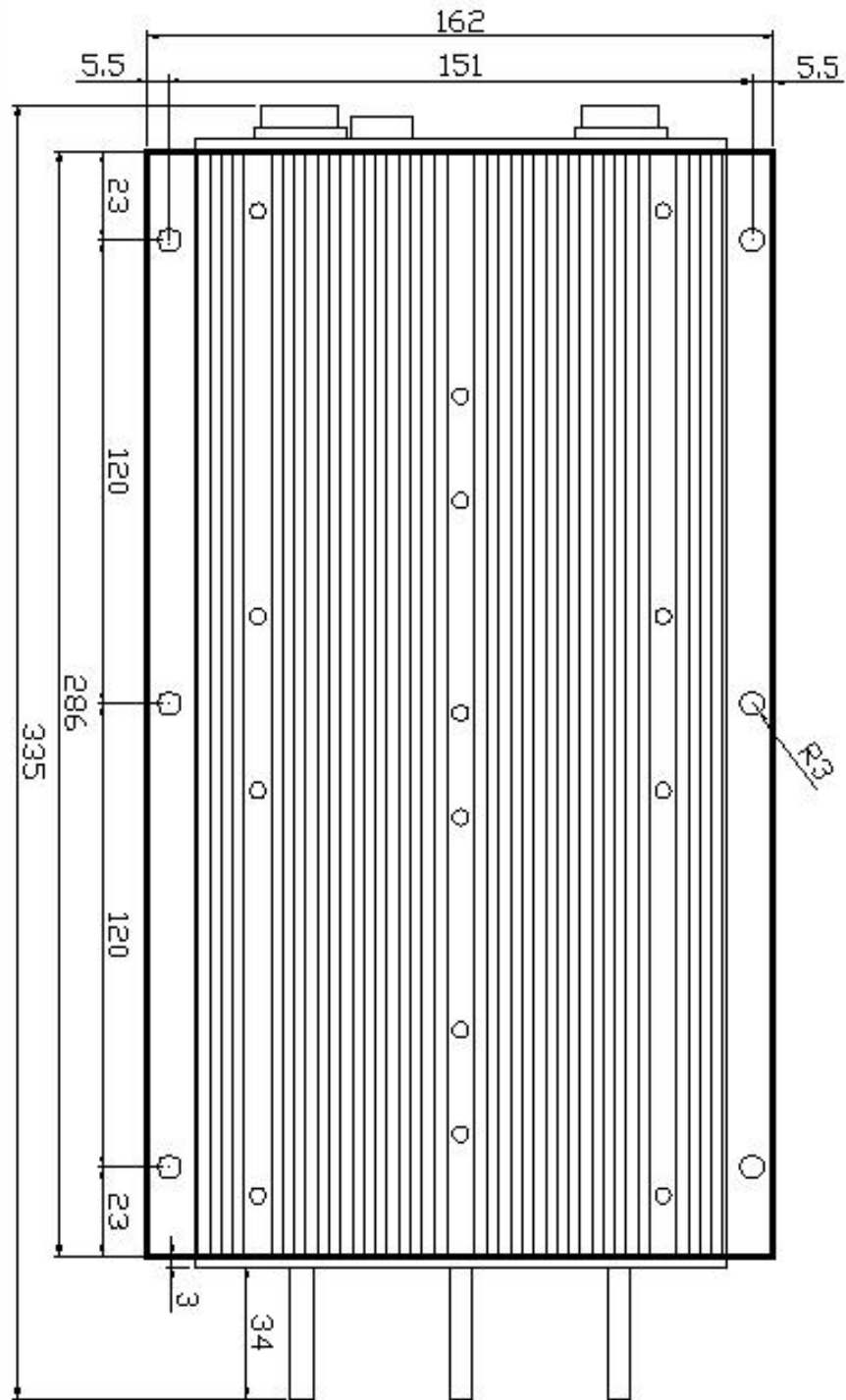

Height: 84 millimeters
 Length: 286 millimeters

Figure 2: KHB mounting holes' dimensions (dimensions in millimeters)

Controller models with above dimension: KHB72701, KHB72101
 KHB12601, KHB12801
 KHB14301, KHB14401

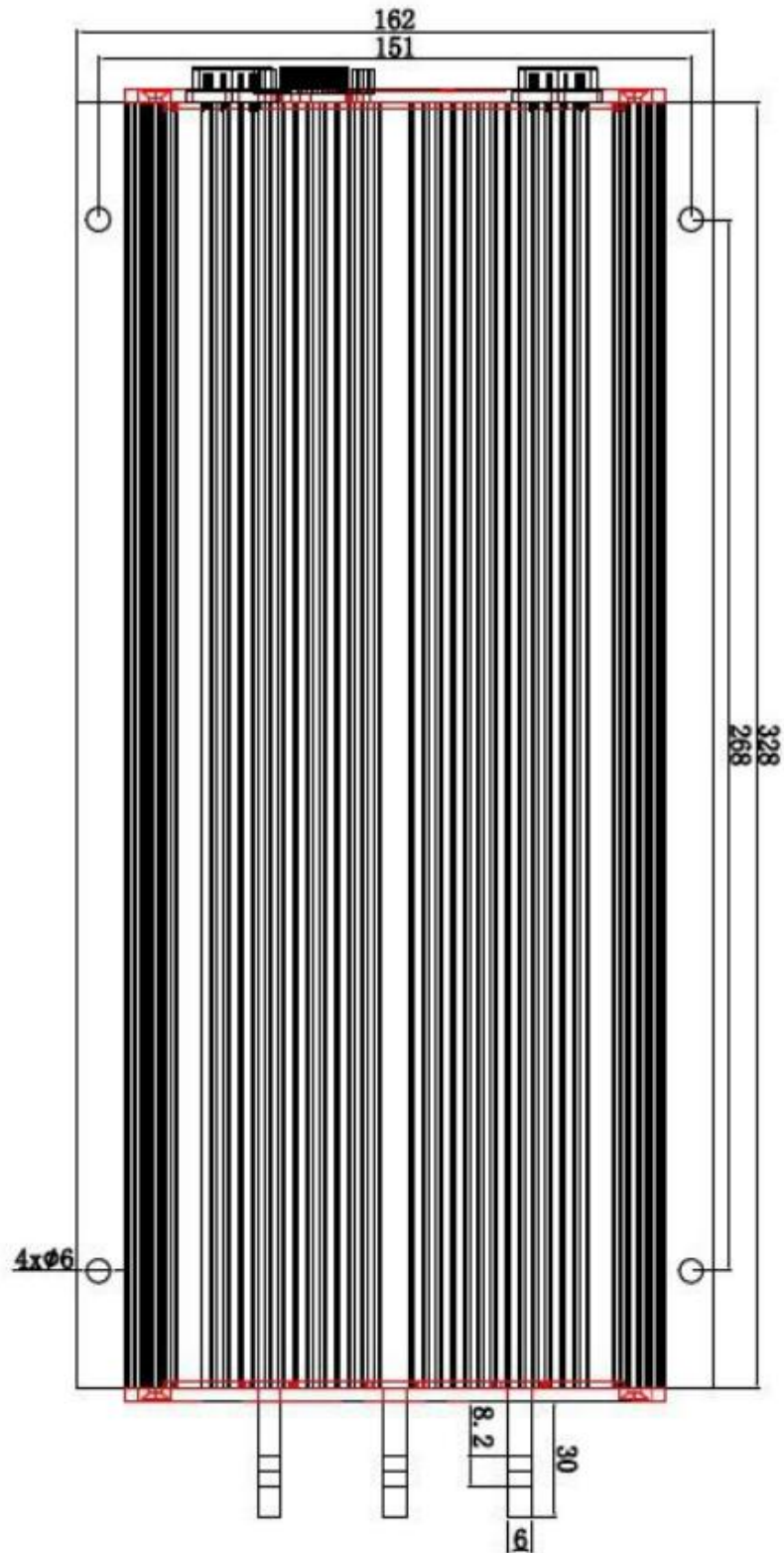

Height: 84 millimeters
 Length: 328 millimeters

Figure 3: KHB mounting holes' dimensions (dimensions in millimeters)
 Controller models with above dimension: KHB14601, KHB12101

3.2 Connections

3.2.1 Front Panel and back panel of KHB Motor Controller:

Five metal bars in front panel and two plugs (J1, J2) in back panel are provided for connecting to the battery, motor and control signals shown as Figure 4,6 and 8.

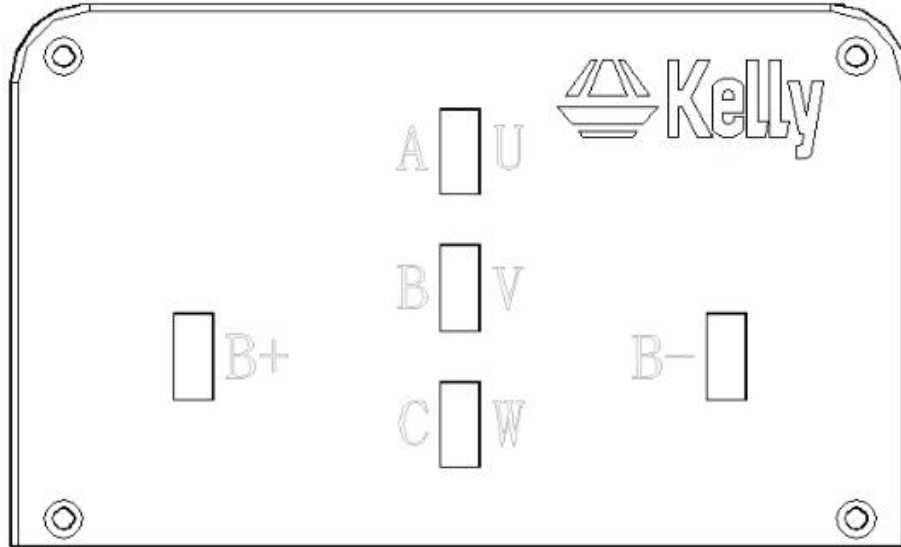

Figure 4: Front panel of KHB motor controller

B+: battery positive

B-: battery negative

A/U: Output A/U phase

B/V: Output B/V phase

C/W: Output C/W phase

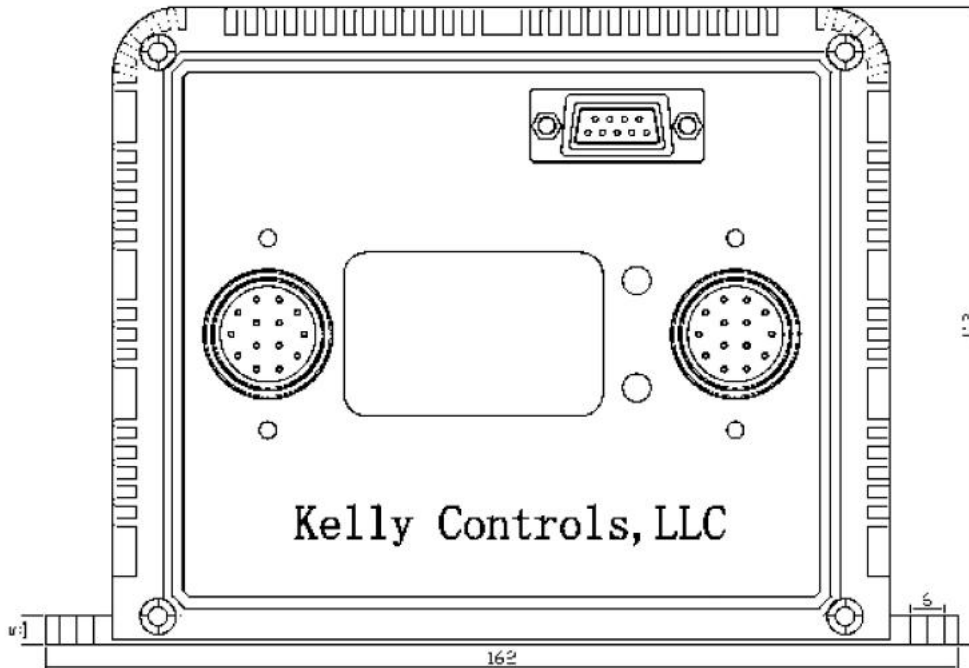

Figure 5: Front panel of KHB14601, KHB12101 motor controller

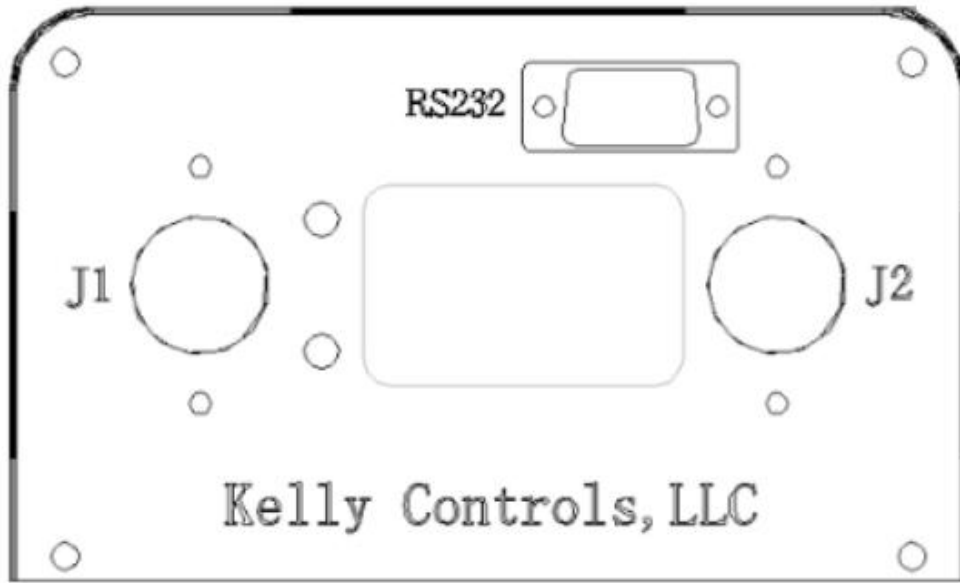

Figure 6: Back panel of KHB motor controller

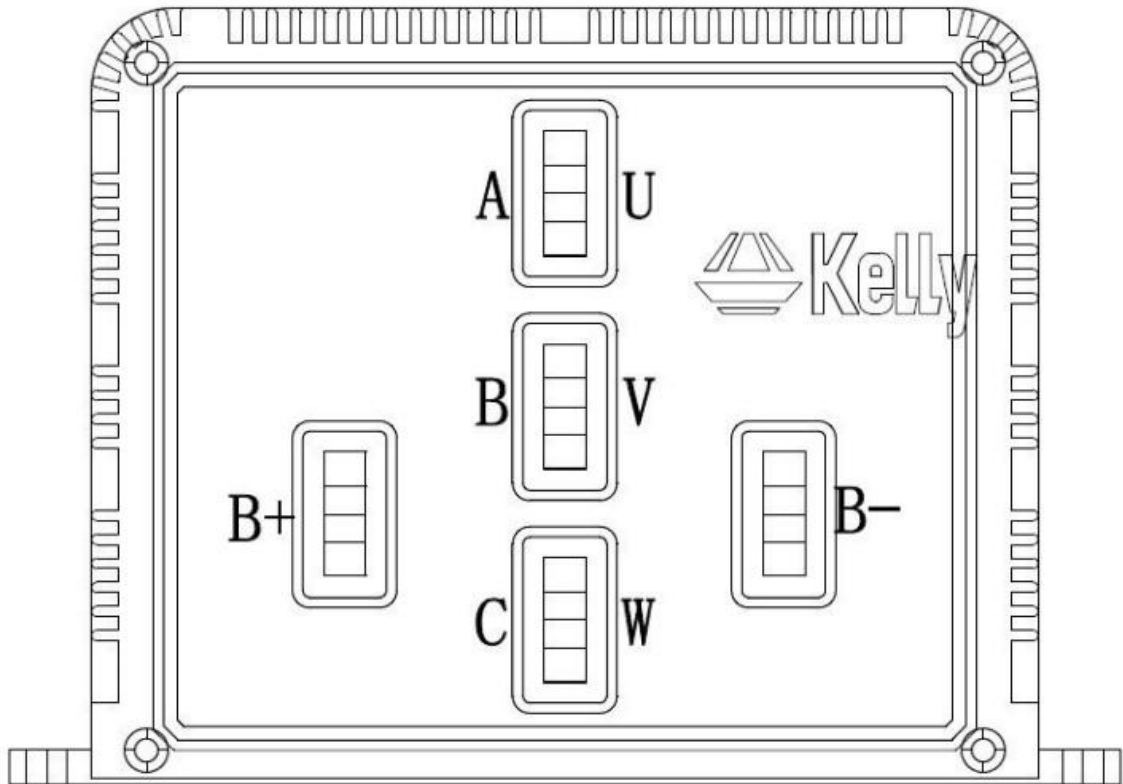

Figure 7: Back panel of KHB14601, KHB12101 motor controller

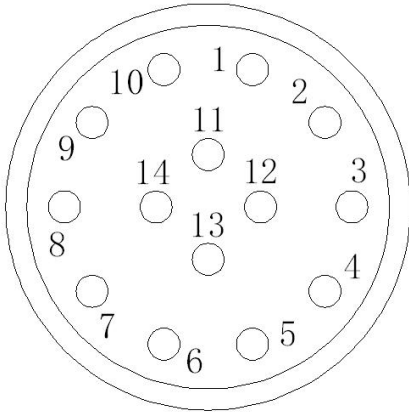

Figure 8: The connecting diagram of J1 and J2

J1 Pin Definition

- 1- PWR: Controller power supply (output).
- 2- Current meter. <200mA
- 3- Main contactor driver. <2A
- 4- Alarm: To drive reverse beeper. <200mA
- 5- RTN: Signal return
- 6- Green LED: Running indication
- 7- RTN: Signal return
- 8- Reserved
- 9- Boost Switch (only available on the controller with 32-bit micro)
- 10- CAN bus high
- 11- CAN bus low
- 12- 12V brake
- 13- RTN: Signal return, or power supply return
- 14- Red LED: Fault code.

J2 Pin Definition

- 1- PWR: Controller power supply (input)
- 2- RTN: Signal return, or power supply return
- 3- RTN: Signal return
- 4- Motor temperature input.
- 5- Throttle analog input, 0-5V
- 6- Brake analog input, 0-5V
- 7- 5V: 5V supply output. <40mA
- 8- Micro_SW: Throttle switch input
- 9- Reversing switch input
- 10- Brake switch input
- 11- Hall phase C
- 12- Hall phase B
- 13- Hall phase A
- 14- RTN: Signal return

Notes:

1. All RTN and GND pins are internally connected, but isolated from B-.
2. Two PWR pins, J1-1 and J2-1, are internally connected. It's recommended to use J1-1 to supply peripherals like alarm and contactor. Twist peripheral wires with PWR is the preferred for EMC.
3. Kelly Ammeter positive connect to 5V power supply of controller, negative to J1-2.
4. Switch to ground is active. Open switch is inactive.

3.2.2 Wiring of KHB Motor Controller

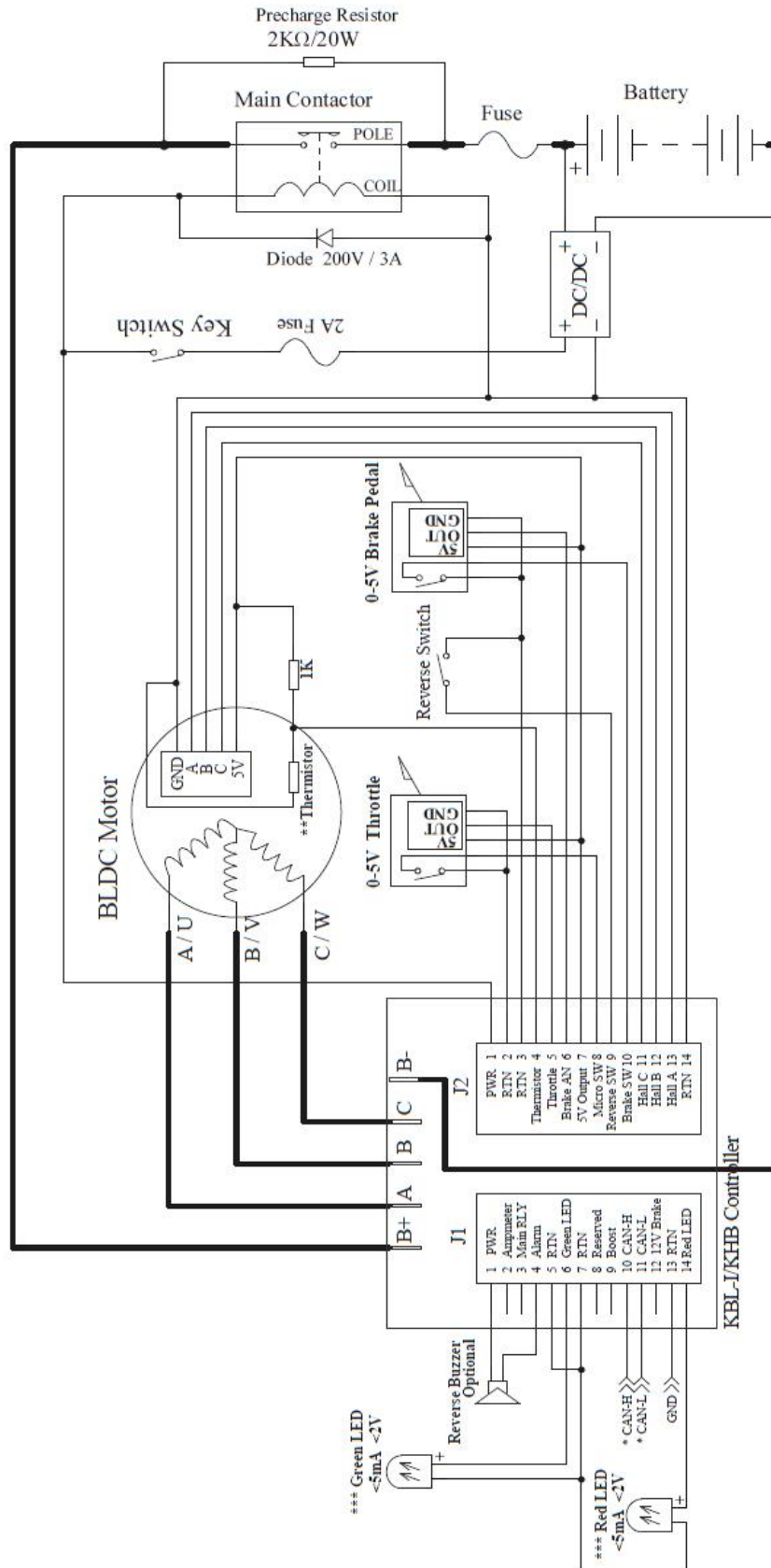

NOTE: 0-5K potentiometer can be used as throttle signal. Wire 5V and RTN to two end terminals, and wiper will output 0-5V signal. Please securely wire B- before any other wiring. Never put contactor or break on B-.
 * CAN bus is deprecated by default.
 ** Thermistor is optional item. default to KTY84-130.
 *** When you connect an external LED, the LED front panel brightness will be reduced.

Figure 9: Standard Wiring for KHB Controllers (12V or 24V battery supply is required)

3.3 Communication Port

A RS232 port is provided to communicate with host computer for calibration and configuration.

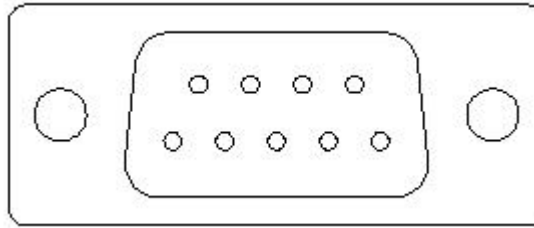

Figure 10: standard RS232 Interface

3.4 Installation Check List

Before operating the vehicle, complete the following checkout procedures. Use LED code as a reference as listed in Table 1.

Caution:

- Put the vehicle up on blocks to get the drive wheels off the ground before beginning these tests.
- Do not allow anyone to stand directly in front of or behind the vehicle during the checkout.
- Make sure the PWR switch and the brake is off
- Use well-insulated tools.

- Make sure the wire is connected correctly
- Turn on the PWR switch, the Red flashes once and the Green is off. After the start-up delay, normally the Red will stay off and the Green will turn on. If there is error, the Red LED will flashes for fault codes.
If the S/N less: 11xxxxxx: Turn on the PWR switch, the Red flashes once and the Green is on. Normally, the Red will stay off. If there is error, the Red LED will flashes for fault codes.
- The fault code will be detected automatically at restart.
- With the brake switch open, select a direction and operate the throttle. The motor should spin in the selected direction. Verify wiring or voltage and the fuse if it does not. The motor should run faster with increasing throttle. If not, refer to the Table 1 LED code, and correct the fault as determined by the fault code.
- Take the vehicle off the blocks and drive it in a clear area. It should have smooth acceleration and good power.

Chapter 4 Maintenance

There are no user-serviceable parts inside the controllers. Do not attempt to open the controller as this will void your warranty. However, periodic, exterior cleaning of the controller should be carried out.

The controller is a high powered device. When working with any battery powered vehicle, proper safety precautions should be taken that include, but are not limited to, proper training, wearing eye protection, avoidance of loose clothing, hair and jewelry. Always use insulated tools.

4.1 Cleaning

Although the controller requires virtually no maintenance after properly installation, the following minor maintenance is recommended in certain applications.

- Remove power by disconnecting the battery, starting with battery positive.
- Discharge the capacitors in the controller by connecting a load (such as a contactor coil, resistor or a horn) across the controller's B+ and B- terminals.
- Remove any dirt or corrosion from the bus bar area. The controller should be wiped down with a moist rag. Make sure that the controller is dry before reconnecting the battery.
- Make sure the connections to the bus bars, if fitted, are tight. To avoid physically stressing the bus bars use two, well-insulated wrenches.

4.2 Configuration

You can configure the controller with a host computer through either an RS232 or USB port.

- Disconnect motor wiring from controller.
- Do not connect B+, throttle and so on. The controller may display fault code in some conditions, but it doesn't affect programming or configuration.
- Use a straight through RS232 cable or Kelly USB To RS232 Converter to connect to a host computer. Provide 10V-30V (either J2 pin1 or J1 pin1) to PWR. Wire power supply return to any RTN pin, isolated from B-.

Download the free configuration software from:

<http://www.kellycontroller.com/support.php>

Caution:

- **Make certain that the motor is disconnected before trying to run the Configuration Software!**
- **Configuration software will be regularly updated and published on the website. Please Update your Configuration Software regularly. You must uninstall the older version before updating.**
- **When setting "Hall Sensor Type" in GUI, do not use "Auto-Check". This has been deleted from the newer configuration software versions.**

Table 1: LED CODES

Green LED Codes

LED Code	Explanation	Solution
Green Off	No power or switched off	1. Check if all wires are correct. 2. Check fuse and power supply.
Green On	Normal operation	That's great! You got solution!
Green & Red are both On		1. Software still upgrading. 2. Supply voltage too low or battery too high 3. The controller is damaged. Contact Kelly about a warranty repair.

Red LED Codes

LED Code	Explanation	Solution
1,2 α αα	Over voltage error	1. Battery voltage is too high for the controller. Check battery volts and configuration. 2. Regeneration over-voltage. Controller will have cut back or stopped regen. 3. This only accurate to $\pm 2\%$ upon Overvoltage setting.
1,3 α ααα	Low voltage error	1. The controller will clear after 5 seconds if battery volts returns to normal. 2. Check battery volts & recharge if required.
1,4 α αααα	Over temperature warning	1. Controller case temperature is above 90°C. Current will be limited. Reduce controller loading or switch Off until controller cools down. 2. Clean or improve heatsink or fan.
2,1 αα α	Motor did not start	Motor did not reach 25 electrical RPM within 2 seconds of start-up. Hall sensor or phase wiring problem.
2,2 αα αα	Internal voltage fault	1. Measure that B+ & PWR are correct when measured to B- or RTN. 2. There may be excessive load on the +5V supply caused by too low a value of Regen or throttle potentiometers or incorrect wiring. 3. Controller is damaged. Contact Kelly about a warranty repair.
2,3 αα ααα	Over temperature	The controller temperature has exceeded 100°C. The controller will be stopped but will restart when temperature falls below 80°C.
2,4 αα αααα	Throttle error at power-up	1. Throttle signal is higher than the preset 'dead zone' at Power On. Fault clears when throttle is

			released. 2. Set throttle model as "Hall Active" throttle in GUI if you use that throttle model.
3,1	aaaa a	Frequent reset	May be caused by over-voltage, bad motor intermittent earthing problem, bad wiring, etc.
3,2	aaaa aa	Internal reset	May be caused by some transient fault condition like a temporary over-current, momentarily high or low battery voltage. This can happen during normal operation.
3,3	aaaa aaaa	Hall throttle is open or short-circuit	When the throttle is repaired, a restart will clear the fault.
3,4	aaaa aaaa	Non-zero throttle on direction change	Controller won't allow a direction change unless the throttle or speed is at zero. Fault clears when throttle is released.
4,1	aaaaa a	Regen or Start-up over-voltage	Motor drive is disabled if an over-voltage is detected at start-up or during regen. The voltage threshold detection level is set during configuration.
4, 2	aaaaa aa	Hall sensor error	1. Incorrect or loose wiring or a damaged hall sensor. 2. Also be caused by incorrect hall angle configuration (60 degree or 120 degree).
4, 3	aaaaa aaaa	Motor over-temperature	Motor temperature has exceeded the configured maximum. The controller will shut down until the motor temperature cools down.

The Red LED flashes once at power on as a confidence check and then normally stays Off. "1, 2" means the Red flashes once and after a second pause, flashes twice. The pause time between multiple flash code groups is two seconds.

Contact Us:

Kelly Controls

Home Page:

<http://www.KellyController.com>

E-mail:

Support@KellyController.com

Phone:

(01) 224 637 5092