

# FX503 Installation Instructions for the Club Car Regen 2



## Before Installation:

- Place rear on jack stands (wheels off the ground)
- Use proper eye protection and tools when working with electrical equipment
- Disconnect the batteries



## Installation:

1. Mount the control (Extra hardware may be required).
2. Connect all motor wires (refer to supplied wiring diagram for proper connection).
3. Move pin 11 of the 23 pin connector to pin 17. (**detailed pictorial instructions on how to do this are on the following pages**).
4. Disconnect the On Board Computer plug and install the adapter harness. (See diagram on page 3.)
5. Plug in charger for 30 seconds.



## Troubleshooting:

Perform all troubleshooting checks with rear wheels off the ground.

### Cart does not operate

- Verify that all wire connections are correct and secure.
- Verify that the Tow switch is in the run position. This can be done by measuring pin 1 on the control.

If switch is closed this pin should measure close to battery volts.

- Verify battery volts on pin 2 of the control.
- Verify approximately 30 volts on pin 6 of the control with the key on.
- Verify approximately battery volts on pin 17 of the control.
- Verify zero volts on pin 3 of the control with no throttle.
- Verify battery volts on pin 3 of the control at full throttle.
- Verify battery volts on pin 4 and zero volts on pin 5 of the control when the forward direction is selected.
- Verify battery volts on pin 5 and zero volts on pin 4 of the control when the reverse direction is selected.
- Verify that control is configured for the correct application (check label).
- If the vehicle has been stored for three days without charging, plug charger in for 30 seconds.

### Contactor closes but no movement

- Verify proper armature and field connections (Refer to supplied wiring diagram).
- Verify approximately 3.5V to 0.5V on pin 7 of the control as the accelerator is slowly depressed.

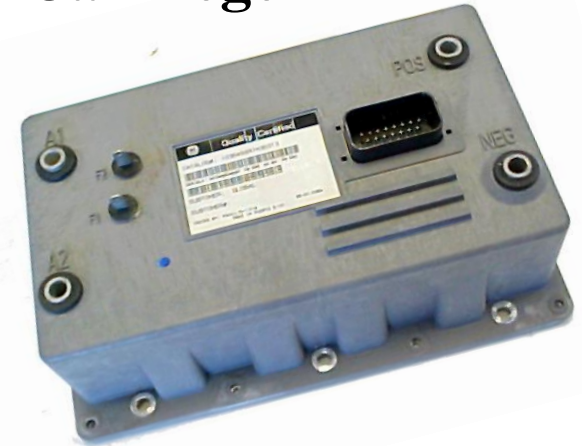

Detailed pictorial instructions, templates, and wiring diagrams can be downloaded from the Golf Cart section of our website.

### Disclaimer:

Flight Systems Industrial Products is not responsible for personal injury or equipment damage due to misuse of the product.



**FLIGHT SYSTEMS  
INDUSTRIAL PRODUCTS**

1015 Harrisburg Pike  
Carlisle, PA 17013  
Phone: (717) 254-3747  
Fax: (717) 254-3777  
Website: [www.fsip.biz](http://www.fsip.biz)

# Instructions for moving pin 11 to pin 17 of the 23 pin connector

1. Pry red insert (from opposite sides of the connector) up and away from black housing of the connector as shown in the pictures below.

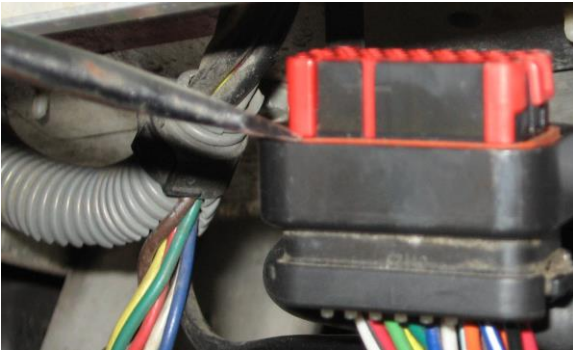

2. Connector should then look like the picture below (notice that the red tab insert is now extended above the black housing of the connector, but not completely dislodged from the connector).

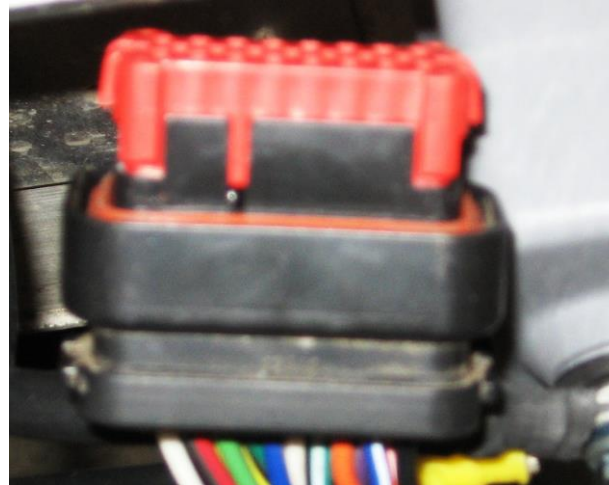

3. With red tab insert extended from housing (as shown above) pull the blue/white wire (pin 11) from the backside of the connector. Pin 11 is shown below.

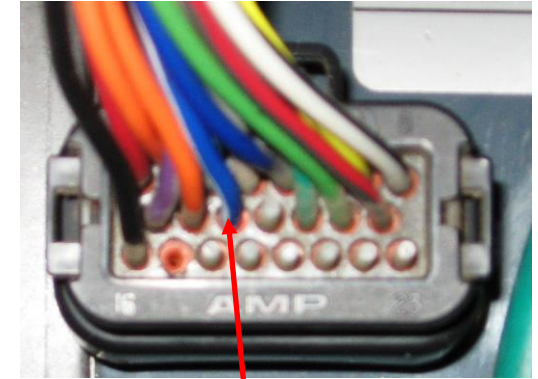

Pin 11

4. Now insert the wire into Pin 17 as shown below.

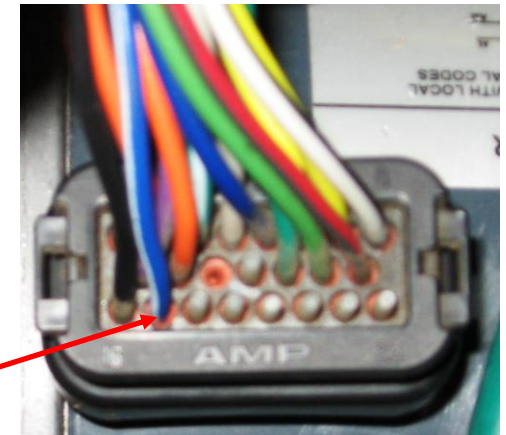
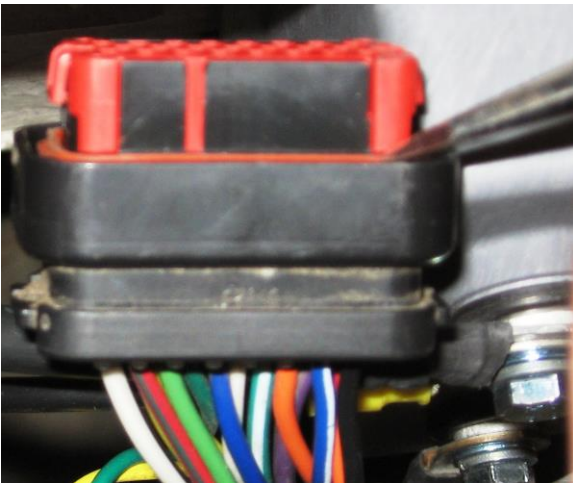

Wire is now inserted into Pin 17.

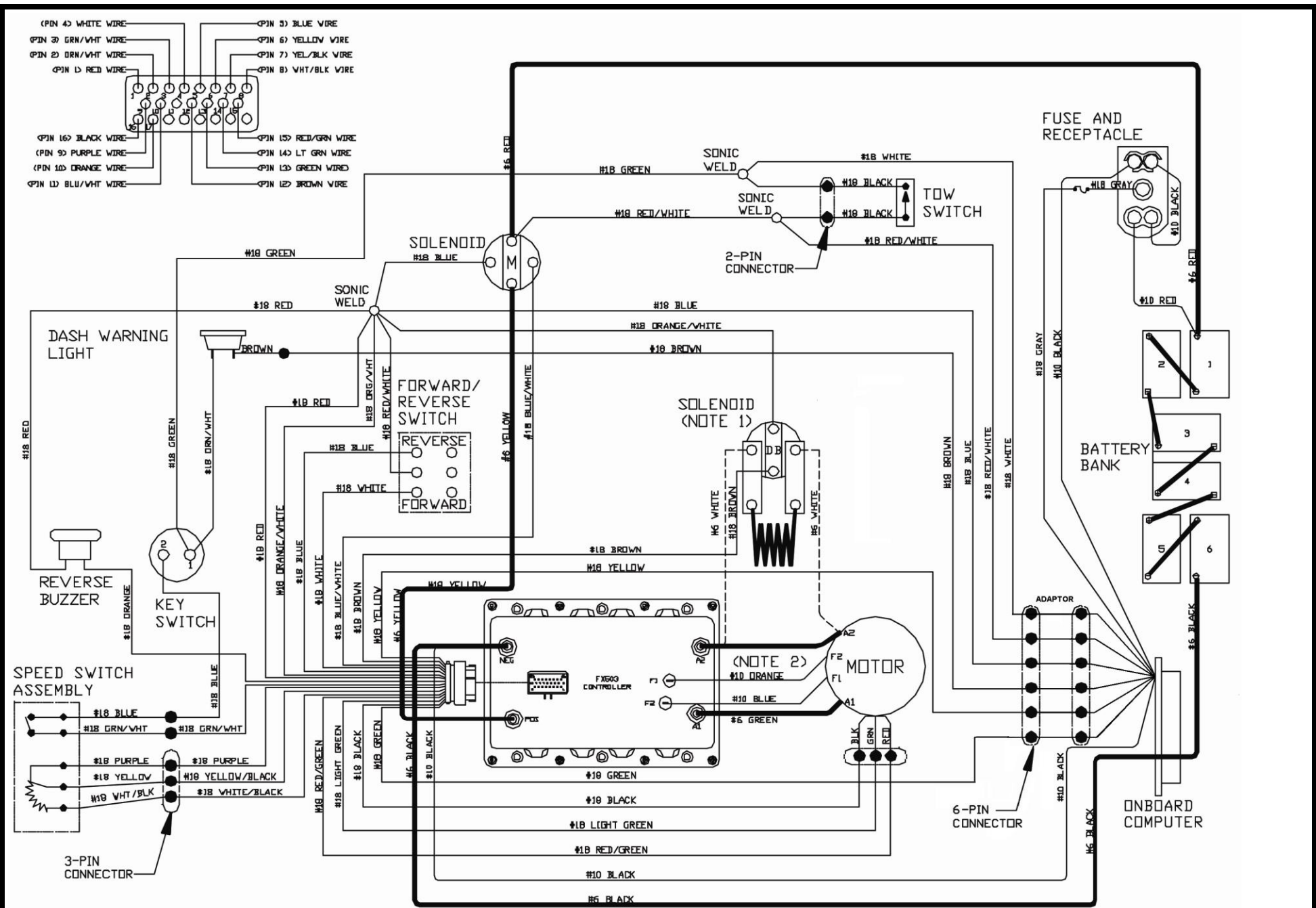

NOTE:  
 1) IF EQUIPPED WITH DYNAMIC BRAKING SOLENOID, REMOVE BOTH #6 WHITE WIRES. USING ONE OF THE WHITE WIRES, CONNECT A2 OF THE CONTROL TO A2 OF THE MOTOR. DISCARD THE OTHER WHITE WIRE (AS SHOWN BY THE DOTTED LINE).  
 2) CONNECT F1 OF THE MOTOR TO F2 OF THE CONTROL AND F2 OF THE MOTOR TO F1 OF THE CONTROL.  
 3) IT IS RECOMMENDED TO REPLACE ALL #6 WIRE WITH #4 OR #2 WIRE.